

# Piezo Engine for Nano Medical Research

Afonin Sergey Mikhailovich

National Research University of Electronic Technology, MIET, 124498, Moscow, Russia.

**\*Corresponding Author:** Afonin Sergey Mikhailovich, National Research University of Electronic Technology, MIET, 124498, Moscow, Russia.

**Received date:** November 07, 2023; **Accepted date:** November 30, 2023; **Published date:** January 22, 2024

**Citation:** Afonin SM, (2024), Piezo Engine for Nano Medical Research. *J. Pharmaceutics and Pharmacology Research*, 7(2);

**DOI:**10.31579/2688-7517/154

**Copyright:** © 2024, Afonin Sergey Mikhailovich. This is an open access article distributed under the Creative Commons Attribution License, which permits unrestricted use, distribution, and reproduction in any medium, provided the original work is properly cited.

## Abstract

The characteristics of the piezo engine are obtained for nano medical research. The transfer coefficient and function on the voltage of the piezo engine are received. The mechanical characteristic of the piezo engine is determined.

**Key words:** piezo engine; deformation; differential equation; characteristic; nano medical research

## Introduction

For nano medical research the piezo engine is applied [1-15]. The energy transformation is clearly for the piezo engine [4-29]. This engine is used in nano medical and pharmaceutics research, X-ray lithography, adaptive optics, nano medicine, scanning probe microscopy.

### Deformation

The equations of the piezo effects [5-52] are written

$$(D) = (d)(T) + (\varepsilon^T)(E)$$

$$(S) = (s^E)(T) + (d)^t(E)$$

here  $(D)$ ,  $(d)$ ,  $(T)$ ,  $(\varepsilon^T)$ ,  $(E)$ ,  $(S)$ ,  $(s^E)$ ,  $(d)^t$  are matrixes for electric induction, piezo constant, strength mechanical field, dielectric constant, strength electric field, relative deformation, elastic compliance and transposed piezo constant. The matrixes for PZT are received

$$(d) = \begin{pmatrix} 0 & 0 & 0 & 0 & d_{15} & 0 \\ 0 & 0 & 0 & d_{15} & 0 & 0 \\ d_{31} & d_{31} & d_{33} & 0 & 0 & 0 \end{pmatrix}$$

$$(s^E) = \begin{pmatrix} s_{11}^E & s_{12}^E & s_{13}^E & 0 & 0 & 0 \\ s_{12}^E & s_{11}^E & s_{13}^E & 0 & 0 & 0 \\ s_{13}^E & s_{13}^E & s_{33}^E & 0 & 0 & 0 \\ 0 & 0 & 0 & s_{55}^E & 0 & 0 \\ 0 & 0 & 0 & 0 & s_{55}^E & 0 \\ 0 & 0 & 0 & 0 & 0 & 2(s_{11}^E - s_{12}^E) \end{pmatrix}$$

$$(\varepsilon^T) = \begin{pmatrix} \varepsilon_{11}^T & 0 & 0 \\ 0 & \varepsilon_{22}^T & 0 \\ 0 & 0 & \varepsilon_{33}^T \end{pmatrix}$$

For the transverse piezo engine its relative deformation [4-29] is obtained

$$S_1 = d_{31}E_3 + s_{11}^E T_1$$

here  $d_{31}$  is the transverse piezo constant.

The differential equation of deformation engine [8-50] is recorded

$$\frac{d^2 \Xi(x, s)}{dx^2} - \gamma^2 \Xi(x, s) = 0$$

here  $\Xi(x, s)$ ,  $x$ ,  $s$ ,  $\gamma = s/c^E + \alpha$ ,  $c^E$ ,  $\alpha$  are the conversion of deformation, the position, the conversion operator, the coefficient of wave propagation, the sound speed, the coefficient of attenuation.

Edge conditions are written

$$\Xi(0, s) = \Xi_1(s) \text{ by } x = 0$$

$$\Xi(h, s) = \Xi_2(s) \text{ by } x = h$$

Decision of differential equation deformation at transverse piezo effect is recorded

$$\Xi(x, s) = \frac{\Xi_1(s) \text{sh}((h-x)\gamma) + \Xi_2(s) \text{sh}(x\gamma)}{\text{sh}(h\gamma)}$$

here  $M_1$ ,  $M_2$  are the masses on its faces.

Structural model and scheme of transverse engine for nano medical research on Figure 1 are found

$$\Xi_1(s) = (M_1 s^2)^{-1} \left\{ -F_1(s) + (\chi_{11}^E)^{-1} \left[ d_{31} E_3(s) - [\gamma/\text{sh}(h\gamma)] \right] \times [\text{ch}(h\gamma)\Xi_1(s) - \Xi_2(s)] \right\}$$

$$\Xi_2(s) = (M_2 s^2)^{-1} \left\{ -F_2(s) + (\chi_{11}^E)^{-1} \left[ d_{31} E_3(s) - [\gamma/\text{sh}(h\gamma)] \right] \times [\text{ch}(h\gamma)\Xi_2(s) - \Xi_1(s)] \right\}$$

$$\chi_{11}^E = s_{11}^E / S_0$$

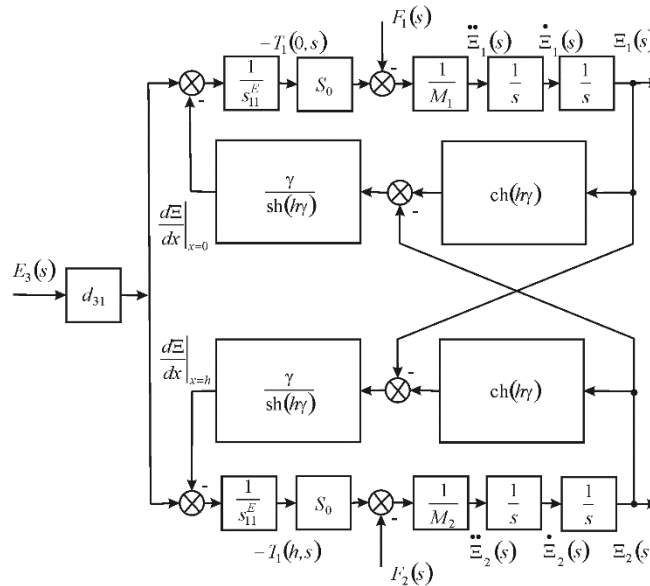

Figure 1. Scheme transverse piezo engine for nano medical research.

For fixed face of engine at  $x = 0$ ,  $\Xi_1(s) = \Xi(0, s) = 0$  the equation of deformation is written

$$\Xi(x, s) = \frac{\Xi_2(s) \text{sh}(x\gamma)}{\text{sh}(h\gamma)}$$

For  $x = h$  the equation is recorded

$$\frac{d\Xi(x, s)}{dx} \Big|_{x=h} = d_{31} E_3(s) - \frac{s_{11}^E M p^2 \Xi_2(s)}{S_0} - \frac{s_{11}^E C_e \Xi_2(s)}{S_0}$$

After conversions

$$\frac{\Xi_2(s)\gamma}{\text{th}(h\gamma)} + \frac{\Xi_2(s)s_{11}^E M s^2}{S_0} + \frac{\Xi_2(s)s_{11}^E C_l}{S_0} = d_{31} E_3(s)$$

For distributed parameters the function is determined in the form

$$W_E(s) = \frac{\Xi_2(s)}{E_3(s)} = \frac{d_{31} h}{M s^2 / C_{11}^E + h\gamma \text{cth}(h\gamma) + C_l / C_{11}^E}$$

here  $C_{11}^E$ ,  $C_l$  are the stiffness of engine and load.

The function on voltage e is obtained

$$W_U(s) = \frac{\Xi_2(s)}{U(s)} = \frac{d_{31} h / \delta}{M p^2 / C_{11}^E + h\gamma \text{cth}(h\gamma) + C_l / C_{11}^E}$$

**Characteristics**

For the lumped parameters at elastic-inertial workload the function on voltage is received in the form

$$W_U(s) = \frac{\Xi_2(s)}{U(s)} = \frac{k_{U31}}{T_t^2 p^2 + 2T_t \xi_t p + 1}$$

here  $k_{U31} = d_{31}(h/\delta) / (1 + C_l / C_{11}^E)$ ,  $T_t = \sqrt{M / (C_l + C_{11}^E)}$ ,

$\omega_t = 1/T_t$ ,  $\xi_t = \alpha l^2 C_{11}^E / (3c^E \sqrt{M(C_l + C_{11}^E)})$  are the transverse

transfer coefficient, the constant of time, the frequency of conjugate and the coefficient of attenuation.

For  $M = 2 \text{ kg}$ ,  $C_l = 0.1 \cdot 10^7 \text{ N/m}$ ,  $C_{11}^E = 0.5 \cdot 10^7 \text{ N/m}$  the parameters PZT engine are found  $T_t = 0.41 \cdot 10^{-3} \text{ s}$  and  $\omega_t = 2.4 \cdot 10^3 \text{ s}^{-1}$  with error 10%.

The steady deformation of the engine at elastic-inertial workload is found

$$\Delta h = \frac{d_{31}(h/\delta)U}{1 + C_l/C_{11}^E} = k_{U31}U$$

At  $d_{31} = 2 \cdot 10^{-10}$  m/V,  $h/\delta = 20$ ,  $C_l/C_{11}^E = 0.2$  for PZT engine its transfer coefficient is received  $k_{U31} = 3.3$  nm/V.

The characteristics of engine are recorded

$$\Delta h = \Delta h_{\max} (1 - F/F_{\max})$$

$$\Delta h_{\max} = d_{31}hE_3 = d_{31}(h/\delta)U$$

$$F_{\max} = d_{31}S_0E_3/s_{11}^E$$

For  $d_{31} = 2 \cdot 10^{-10}$  m/V,  $E_3 = 1.5 \cdot 10^5$  V/m,  $h = 2.5 \cdot 10^{-2}$  m,  $S_0 = 1.5 \cdot 10^{-5}$  m<sup>2</sup>,  $s_{11}^E = 15 \cdot 10^{-12}$  m<sup>2</sup>/N parameters PZT engine are determined

$$\Delta h_{\max} = 750 \text{ nm and } F_{\max} = 30 \text{ N.}$$

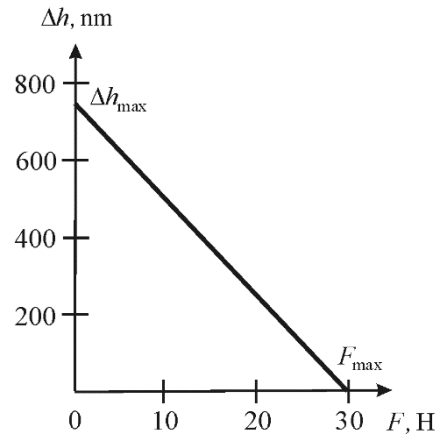

Figure 2. Mechanical characteristic of engine.

## Conclusions

The parameters of the piezo engine are obtained. For nano medical research the transfer coefficient and function on the voltage are found. The mechanical characteristic of the piezo engine is determined.

## References

1. Uchino K (1997) Piezoelectric actuator and ultrasonic motors. Boston, MA: Kluwer Academic Publisher. 350.
2. Afonin SM (2006) Absolute stability conditions for a system controlling the deformation of an electromagnetoelastic transducer. Doklady Mathematics 74(3): 943-948,
3. Schultz J, Ueda J, Asada H (2017) Cellular Actuators. Butterworth-Heinemann Publisher, Oxford, 382.
4. Afonin SM (2005) Generalized parametric structural model of a compound electromagnetoelastic transducer. Doklady Physics 50(2): 77-82.
5. Afonin SM (2008) Structural parametric model of a piezoelectric nanodisplacement transducer. Doklady Physics 53(3): 137-143.
6. Afonin SM (2006) Solution of the wave equation for the control of an electromagnetoelastic transducer. Doklady Mathematics 73(2): 307-313.
7. Cady WG (1946) Piezoelectricity: An introduction to the theory and applications of electromechanical phenomena in crystals. McGraw-Hill Book Company, New York, London, 806.
8. Mason W, editor (1964) Physical Acoustics: Principles and Methods. Vol.1. Part A. Methods and Devices. Academic Press, New York, 515.
9. Y. Yang, L. Tang (2009) Equivalent circuit modeling of piezoelectric energy harvesters. Journal of Intelligent Material Systems and Structures 20(18): 2223-2235.
10. Zwillinger D (1989) Handbook of Differential Equations. Academic Press, Boston, 673.
11. Afonin SM (2006) A generalized structural-parametric model of an electromagnetoelastic converter for nano- and micrometric movement control systems: III. Transformation parametric structural circuits of an electromagnetoelastic converter for nano- and micrometric movement control systems, Journal of Computer and Systems Sciences International 45(2): 317-325.
12. Afonin SM (2006) Generalized structural-parametric model of an electromagnetoelastic converter for control systems of nano- and micrometric movements: IV. Investigation and calculation of characteristics of step-piezodrive of nano- and micrometric movements. Journal of Computer and Systems Sciences International 45(6): 1006-1013.
13. Afonin SM (2016) Decision wave equation and block diagram of electromagnetoelastic actuator nano- and microdisplacement for communications systems. International Journal of Information and Communication Sciences 1(2): 22-29.
14. Afonin SM (2015) Structural-parametric model and transfer functions of electroelastic actuator for nano- and microdisplacement. Chapter 9 in Piezoelectrics and Nanomaterials: Fundamentals, Developments and Applications. Ed. Parinov IA. Nova Science, New York. 225-242.
15. Afonin SM (2017) A structural-parametric model of electroelastic actuator for nano- and microdisplacement of mechatronic system. Chapter 8 in Advances in Nanotechnology. Volume 19. Eds. Bartul Z, Trenor J, Nova Science, New York, 259-284.
16. Afonin SM (2018) Electromagnetoelastic nano- and microactuators for mechatronic systems. Russian Engineering Research 38(12): 938-944.
17. Afonin SM (2012) Nano- and micro-scale piezomotors. Russian Engineering Research 32(7-8): 519-522.
18. Afonin SM (2007) Elastic compliances and mechanical and adjusting characteristics of composite piezoelectric transducers, Mechanics of Solids 42(1): 43-49.
19. Afonin SM (2014) Stability of strain control systems of nano- and microdisplacement piezotransducers. Mechanics of Solids 49(2): 196-207.
20. Afonin SM (2017) Structural-parametric model electromagnetoelastic actuator nanodisplacement for mechatronics. International Journal of Physics 5(1): 9-15.
21. Afonin SM (2019) Structural-parametric model multilayer electromagnetoelastic actuator for nanomechatronics. International Journal of Physics 7(2): 50-57.

22. Afonin SM (2021) Calculation deformation of an engine for nano biomedical research. *International Journal of Biomed Research* 1(5): 1-4.
23. Afonin SM (2021) Precision engine for nanobiomedical research. *Biomedical Research and Clinical Reviews* 3(4): 1-5.
24. Afonin SM (2016) Solution wave equation and parametric structural schematic diagrams of electromagnetoelastic actuators nano- and microdisplacement. *International Journal of Mathematical Analysis and Applications* 3(4): 31-38.
25. Afonin SM (2018) Structural-parametric model of electromagnetoelastic actuator for nanomechanics. *Actuators* 7(1): 1-9.
26. Afonin SM (2019) Structural-parametric model and diagram of a multilayer electromagnetoelastic actuator for nanomechanics. *Actuators* 8(3): 1-14.
27. Afonin SM (2016) Structural-parametric models and transfer functions of electromagnetoelastic actuators nano- and microdisplacement for mechatronic systems. *International Journal of Theoretical and Applied Mathematics* 2(2): 52-59.
28. Afonin SM (2010) Design static and dynamic characteristics of a piezoelectric nanomicrotransducers. *Mechanics of Solids* 45(1): 123-132.
29. Afonin SM (2018) Electromagnetoelastic Actuator for Nanomechanics. *Global Journal of Research in Engineering: A Mechanical and Mechanics Engineering* 18(2): 19-23.
30. Afonin SM (2018) Multilayer electromagnetoelastic actuator for robotics systems of nanotechnology, *Proceedings of the 2018 IEEE Conference EIconRus*, 1698-1701.
31. Afonin SM (2018) A block diagram of electromagnetoelastic actuator nanodisplacement for communications systems. *Transactions on Networks and Communications* 6(3): 1-9.
32. Afonin SM (2019) Decision matrix equation and block diagram of multilayer electromagnetoelastic actuator micro and nanodisplacement for communications systems, *Transactions on Networks and Communications* 7(3): 11-21.
33. Afonin SM (2020) Condition absolute stability control system of electromagnetoelastic actuator for communication equipment. *Transactions on Networks and Communications* 8(1): 8-15.
34. Afonin SM (2020) A Block diagram of electromagnetoelastic actuator for control systems in nanoscience and nanotechnology, *Transactions on Machine Learning and Artificial Intelligence* 8(4): 23-33.
35. Afonin SM (2020) Optimal control of a multilayer electroelastic engine with a longitudinal piezoeffect for nanomechanics systems. *Applied System Innovation* 3(4): 1-7.
36. Afonin SM (2021) Coded control of a sectional electroelastic engine for nanomechanics systems. *Applied System Innovation* 4(3): 1-11.
37. Afonin SM (2020) Structural scheme actuator for nano research. *COJ Reviews and Research* 2(5): 1-3.
38. Afonin SM (2018) Structural-parametric model electroelastic actuator nano- and microdisplacement of mechatronics systems for nanotechnology and ecology research. *MOJ Ecology and Environmental Sciences* 3(5): 306-309.
39. Afonin SM (2018) Electromagnetoelastic actuator for large telescopes. *Aeronautics and Aerospace Open Access Journal* 2(5): 270-272.
40. Afonin SM (2019) Condition absolute stability of control system with electro elastic actuator for nano bioengineering and microsurgery. *Surgery & Case Studies Open Access Journal* 3(3): 307-309.
41. Afonin SM (2019) Piezo actuators for nanomedicine research. *MOJ Applied Bionics and Biomechanics* 3(2): 56-57.
42. Afonin SM (2019) Frequency criterion absolute stability of electromagnetoelastic system for nano and micro displacement in biomechanics. *MOJ Applied Bionics and Biomechanics* 3(6): 137-140.
43. Afonin SM (2020) Multilayer piezo engine for nanomedicine research. *MOJ Applied Bionics and Biomechanics* 4(2): 30-31.
44. Afonin SM (2020) Multilayer engine for microsurgery and nano biomedicine. *Surgery & Case Studies Open Access Journal* 4(4): 423-425.
45. Afonin SM (2019) A structural-parametric model of a multilayer electroelastic actuator for mechatronics and nanotechnology. Chapter 7 in *Advances in Nanotechnology*. Volume 22. Eds. Bartul Z, Trenor J, Nova Science, New York, 169-186.
46. Afonin SM (2020) Electroelastic digital-to-analog converter actuator nano and microdisplacement for nanotechnology. Chapter 6 in *Advances in Nanotechnology*. Volume 24. Eds. Bartul Z, Trenor J, Nova Science, New York. 205-218.
47. Afonin SM (2021) Characteristics of an electroelastic actuator nano- and microdisplacement for nanotechnology. Chapter 8 in *Advances in Nanotechnology*. Volume 25. Eds. Bartul Z, Trenor J, Nova Science, New York. 251-266.
48. Afonin SM (2021) Rigidity of a multilayer piezoelectric actuator for the nano and micro range. *Russian Engineering Research* 41(4): 285-288.
49. Afonin SM (2020) Structural scheme of electroelastic actuator for nanomechanics, Chapter 40 in *Advanced Materials*. *Proceedings of the International Conference on "Physics and Mechanics of New Materials and Their Applications"*, PHENMA 2019. Eds: Parinov IA, Chang SH, Long BT. Springer, Switzerland, Cham. 487-502.
50. Afonin SM (2021) Absolute stability of control system for deformation of electromagnetoelastic actuator under random impacts in nanoresearch. Chapter 43 in *Physics and Mechanics of New Materials and Their Applications*. PHENMA 2020. Springer *Proceedings in Materials*. Volume 10. Eds. Parinov IA, Chang SH, Kim YH, Noda NA. Springer, Switzerland, Cham. 519-531.
51. Nalwa HS, editor (2004) *Encyclopedia of Nanoscience and Nanotechnology*. Los Angeles: American Scientific Publishers. 10 Volumes.
52. Bhushan B, editor (2004) *Springer Handbook of Nanotechnology*. New York: Springer, 1222.



This work is licensed under Creative Commons Attribution 4.0 License

To Submit Your Article Click Here:

[Submit Manuscript](#)

DOI: [10.31579/2688-7517/154](https://doi.org/10.31579/2688-7517/154)

**Ready to submit your research? Choose Auctores and benefit from:**

- fast, convenient online submission
- rigorous peer review by experienced research in your field
- rapid publication on acceptance
- authors retain copyrights
- unique DOI for all articles
- immediate, unrestricted online access

At Auctores, research is always in progress.

Learn more <https://auctoresonline.org/journals/pharmaceutics-and-pharmacology-research>